

Motorsport Measurements

Dan Hobbs
Kugann Ramachandran

Stock Car Sway Bar Rate Tester

ABE 485 – April, 2008



Objective:

Team will design and build prototype stock car anti-roll bar rate testing device.

- Emphasis will be on economy to offer testing abilities to wider range of race teams with limited testing budgets.
- Device will accurately determine the torsional spring rate of sway bar and arm system.
- Information gathered will allow crew chiefs to approach ideal vehicle setup for each race track.

Introduction to Problem:

Definition of Sway Bar:

Often called an “anti-roll bar”, a sway bar acts to resist the forces causing body roll when a vehicle encounters a lateral force. It does so as a torsional spring, connected to each lower control arm of an independent suspension, by equal length perpendicular arms.

As the right front suspension moves up relative to the chassis (Fig. 2), the right arm is pulled up, causing a reaction on the equivalent point of the left front suspension (Fig 3).



Figure 1 - Sway Bar and Arm System in Plan View.

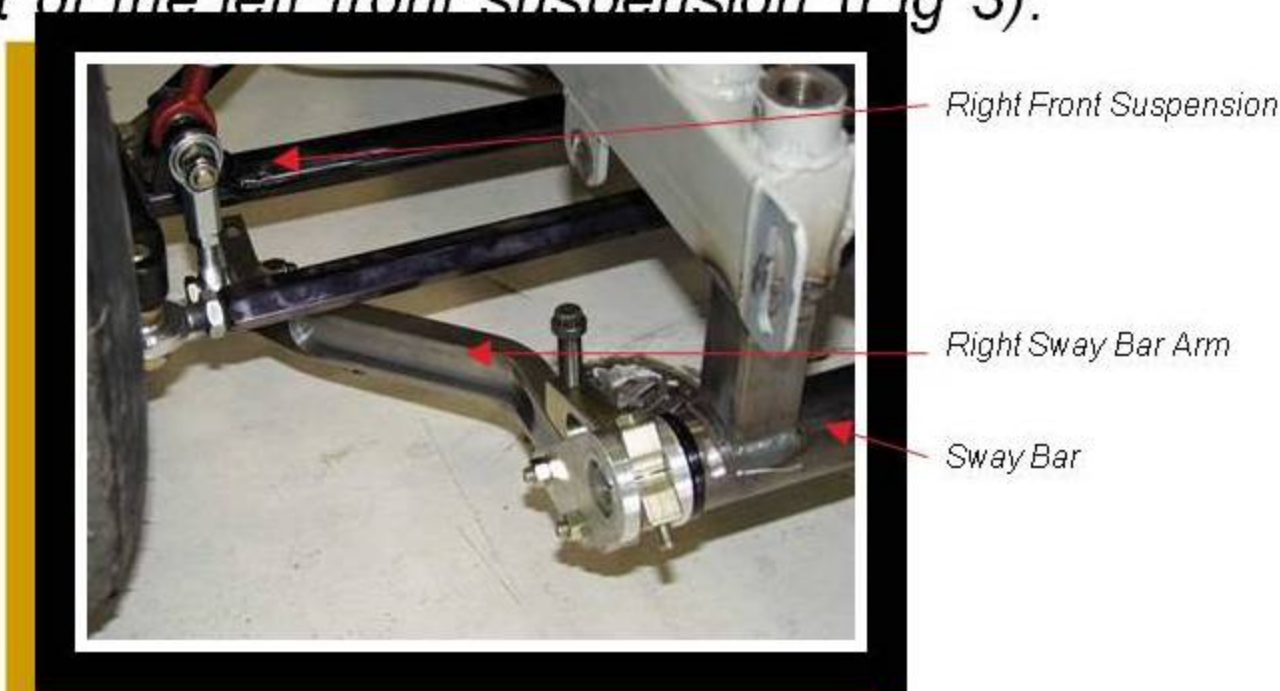

Figure 2 - Right Front Sway Bar Mounting

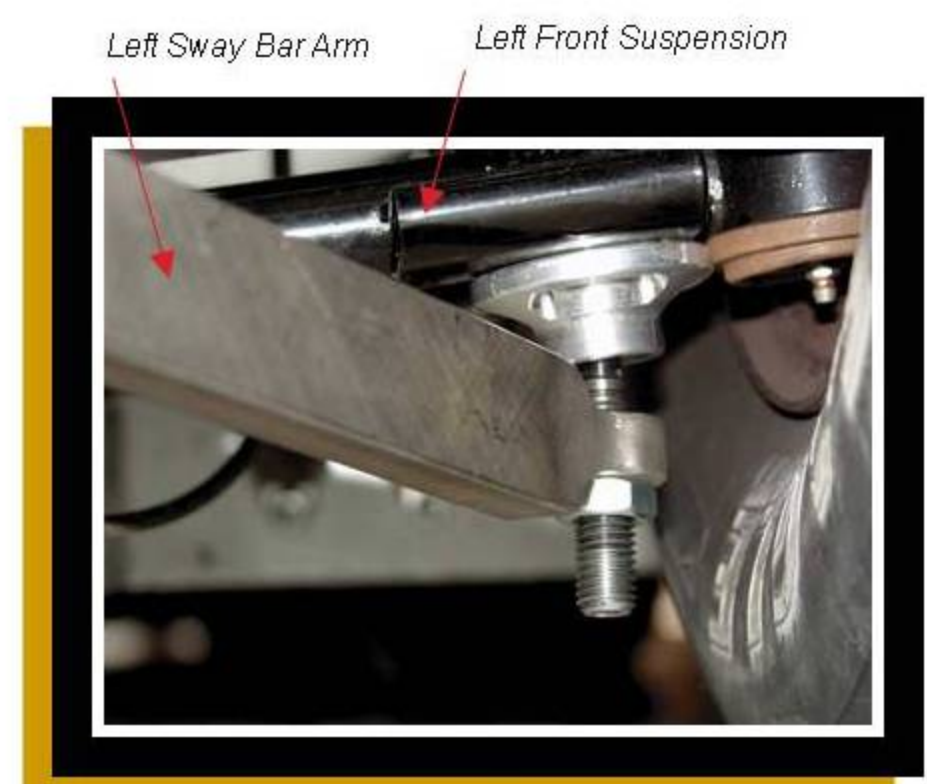

Figure 3 - Left Front Sway Bar Mounting

Importance to Racing:

- The fundamental problem posed by racing is to develop maximum lateral force by each of the four tire contact patches.
- Lateral force production is based directly on normal loads applied to each contact patch, and maximizing total lateral force production of the vehicle requires control of the vertical loads applied to each tire.
- Control of load transfer onto outside tire and off of inside tire due to lateral accelerations is critical, as axle will generate peak lateral force at equal left and right slip angles.
- Sway bar also controls roll angle of the vehicle as presented to the air, as excessive roll can cause valence to raise, increasing aerodynamic drag and decreasing overall front downforce.
- Torsional stiffness of sway bar controls the amount of body roll and load transfer, larger diameter bars and shorter arms providing maximum roll resistance. A vehicle with an improper front roll resistance is shown in Fig 4.



Figure 4 - Vehicle Experiencing Excessive Roll

Design Concept:

Method of Testing:

- Output of equipment will be a resistance to torsion in pounds, at inches of deflection from co-planar of two arms.
- Hydraulic cylinder will actuate right arm up to three inches, providing a maximum of 5,000 lbf. While left arm is fixed, with pre-load.
- Digital height gauge will measure stroke of cylinder, providing user with torsional spring rate of bar at all points through test range.
- Device will accommodate variety of arm lengths, between 10 and 18 inches, and variety of bar diameters, up to 2-1/8".

Final Specification:

- Baseplate was initially specified as 1/4" plate, but will require sub-surface structural support to limit deflection at peak loading (Fig 6).
- Baseplate will be of 1/4" plate stock, 48" x 24", with 3"x1"x1/8" wall structural support below, limiting peak deflection to 0.070".
- Sway bar eyelets will be of 7/8" 9-thread stock, adjustable in length for different arm configurations.
- Eyelets are 2-1/8" I.D. and plastic bushings for various bar diameters will be produced.
- Cylinder will be mounted on sliding plate, with 4" digital height gauge (not shown) attached to cylinder.
- 3" C-Clamp will be used to hold arm fixed, allowing for addition of pre-load into bar.

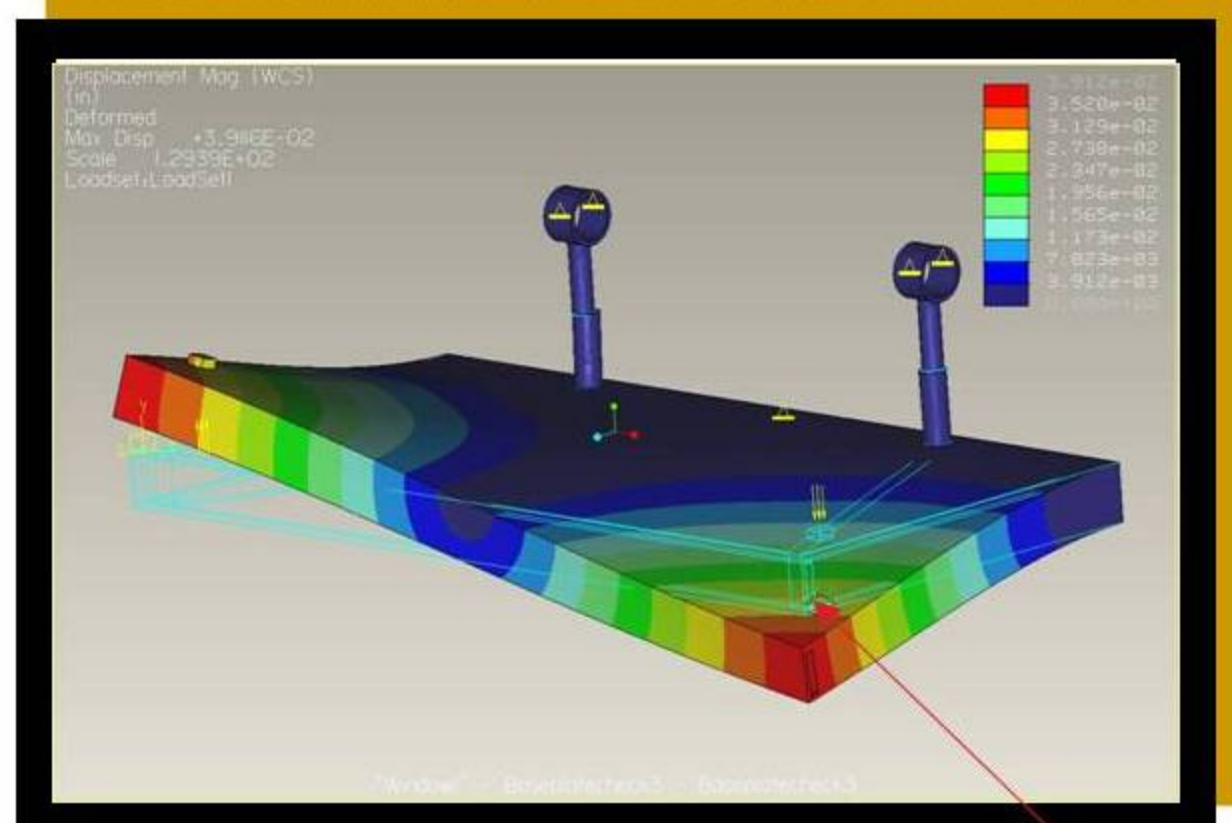
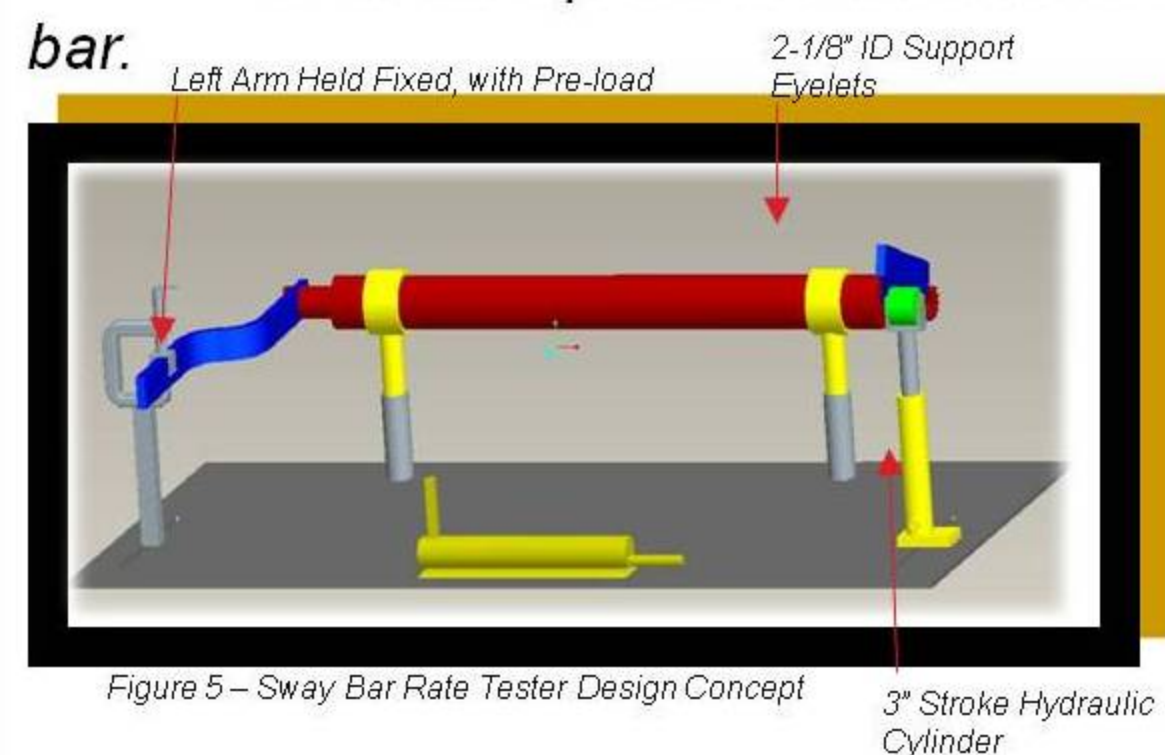

Figure 6 – Deflection at Peak Loading

Total Displacement of Loaded Points Below 0.070"

Progress:

- Market Research, Design Conceptualization, Component Specification Complete
- Construction is in progress.
- Testing and Reporting to follow.

Acknowledgements:

- Dr. Joseph Irudayaraj, Professor of Agricultural and Biological Engineering.
- Mr. Brad Cook, General Manager, Aluminum Racing Products Inc.